

Jason International, Inc.  
8328 MacArthur Drive  
North Little Rock, AR 72118  
www.jasoninternational.com



49-1000-301  
Date 02/08

## OWNER'S MANUAL

# Carrera™ Collection Lavatory INSTALLATION, OPERATION, AND MAINTENANCE

### INSPECTION

Inspecting the unit prior to installation is the responsibility of the installer. The unit is cleaned and inspected prior to leaving the factory.

Damage sustained in transit is the responsibility of the carrier. The owner or installer **MUST** open, uncrate, and inspect the unit for damage when it is delivered. If damage is discovered, the carrier must be immediately notified in writing with a request for a representative to inspect the unit. Failure of the carrier to respond should be reported to the seller and carrier. Always file a freight claim promptly.

The installer is responsible for insuring that the unit is free from defects or shipping damage. In the event of a problem, **DO NOT** install the unit. The factory is not responsible for damage that might have been avoided by inspection or testing prior to installation.

Damage to the unit during installation will not be covered by warranty and is the responsibility of the installer. **ALL WARRANTY CLAIMS ON CARRERA™ COMPOSITE SURFACE DAMAGE MUST BE MADE PRIOR TO INSTALLATION.** Inspect the bath for damage. Alert your dealer of any discrepancies.

To protect the unit from damage, keep the unit in its carton until ready for installation.

**Table 1 - Specifications**

Model	Overall Dimensions L x W x H (In.)
CL100	17.5" (dia.) x 6"
CL200	14" x 22" x 4 1/2"

### OWNER'S RECORD

Dealer: \_\_\_\_\_

Date Purchased: \_\_\_\_\_

Date Installed: \_\_\_\_\_

Installer: \_\_\_\_\_

**PLACE SERIAL NUMBER CARD WITH  
PRODUCT CONFIGURATION IN THIS BOX**

# INSTALLATION INSTRUCTIONS

These instructions are to be followed in installing the lavatory. Electrical connection is not needed.

See the **USER MAINTENANCE INSTRUCTIONS** on page 3 for humidity and mold prevention suggestions prior to installation.

## LOCATING THE LAVATORY

Establish the location of the lavatory and use the dimensions provided in Figure 2 to cut and drill the drain and mounting holes.

**NOTE:** The center of the CL100 (Round) lavatory must be at least ten (10) inches (25.4cm) from the back wall to prevent interference between the lavatory and the wall. The CL200 must be six (6) inches from the wall.

1. The outside circle on **Figure 2** is the outside rim of the lavatory. Allow adequate space between the wall and the rim for faucet hardware.
2. Cut or punch through to mark the countertop for the drain and the four mounting holes. The drain hole circles in **Figure 2** show a three (3) inch cut-out.

## DRILLING THE DRAIN AND MOUNTING HOLES.

1. Drill four 1/4" diameter holes at the marked locations for the mounting holes.

2. Use a saber saw to cut the drain hole in the countertop as marked.
3. Install the drain.

The lavatory is now ready to be set.

## SETTING THE LAVATORY

1. Place the lavatory upside down on a soft, protected surface and attach the four #10-24 mounting studs to the bottom of the lavatory.

**Caution! Do not support the lavatory by the mounting studs at any time.**

2. Apply a 1/8" (3mm) bead of silicone sealant to the inside perimeter of the base, as indicated in **Figure 2**. Also apply sealant around the drain and the four mounting holes.
3. Flip the lavatory over and use the mounting studs to guide the lavatory into position.
4. Once the lavatory is resting on the countertop, attach with the four washers and nuts to secure it in place.

Allow 24 hours before using the lavatory to insure the sealant is fully cured.

Figure 1

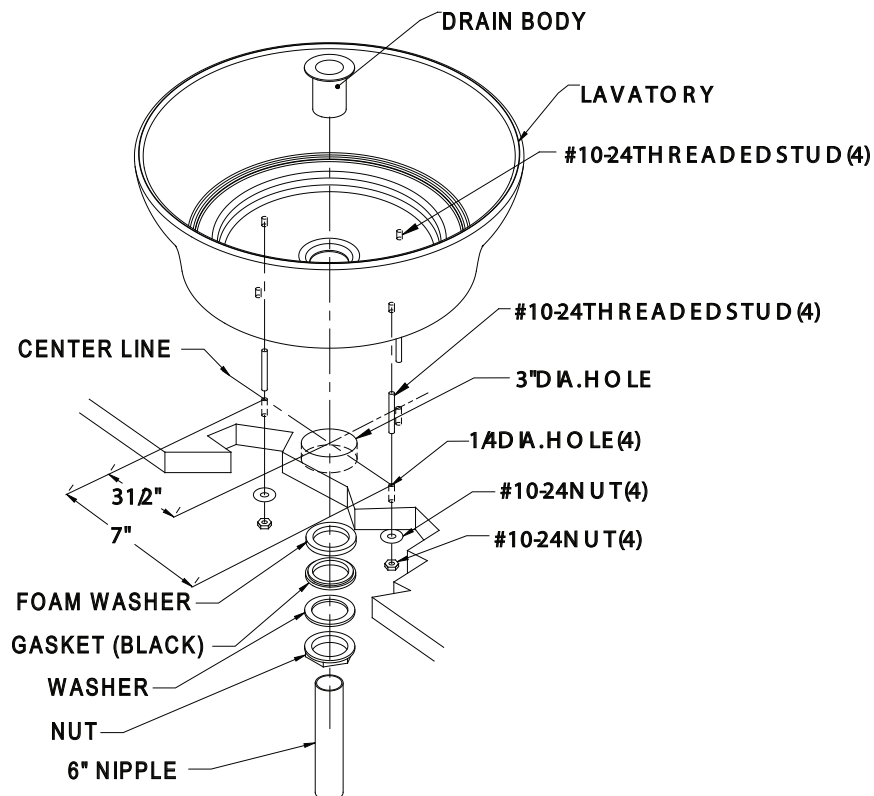

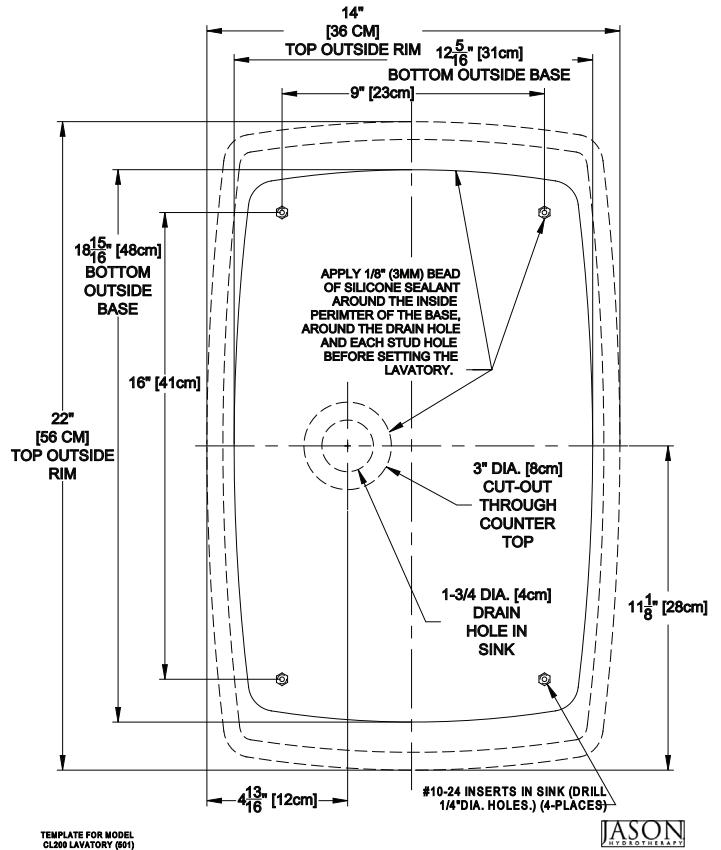
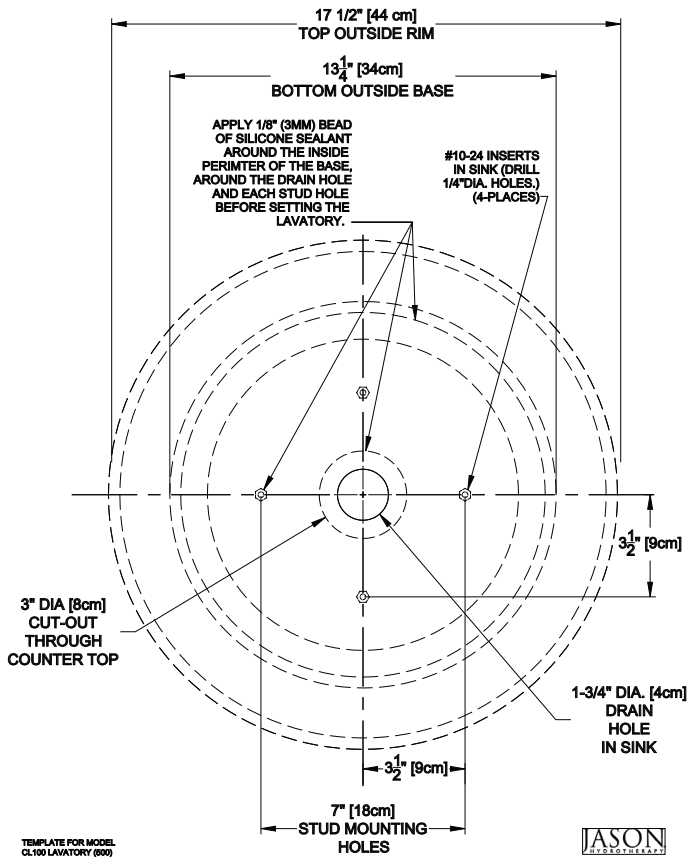

Figure 2

## USER MAINTENANCE INSTRUCTIONS

### CLEANING and SURFACE MAINTENANCE

The Carrera™ Composite solid surface is nonporous. Stains, mold, mildew, or bacteria cannot penetrate the surface.

When frequently cleaned, the Carrera™ Composite solid surface will maintain its original beauty and resist any signs of wear and aging for years to come. Since the Carrera™ Composite solid surface is homogeneous and evenly solid, surface damage can be easily removed by using extra fine abrasive paper and cleaning with traditional abrasive detergents.

For most dirt and residue, use soapy water or ammonia cleaner; rinse; and wipe dry. For the occasional stubborn residue, use a cleaner like Clorox Soft Scrub and a 3M Scotch Brite pad (green) to remove the residue.

Occasional disinfecting can be preformed by wiping the surface with diluted household bleach (1 part water and 1 part bleach). Rinse the surface with water and wipe dry. When using a bleach solution, care must taken not to get any in your eyes or on bare skin. You should always wear gloves and eye protection when working with bleach.

The Carrera™ Composite solid surface should not be exposed to strong chemicals, such as, paint remover, oven cleaners, hydrochloric acid, sodium hydroxide, chloride solvents (trichloroethylene), or any strong acids or bases.

### REPAIR

Refer all plumbing or surface repair to a qualified service technician. Remember when contacting your dealer or service representative to always have your serial number, proof of purchase, and model number. This will ensure a quick response on warranty items. The serial number can be found on the small label adhered to the outside of the lavatory.

**PLEASE NOTE: ALL WARRANTY REPAIRS MUST BE AUTHORIZED BY THE MANUFACTURER BEFORE WORK IS STARTED.**

## JASON INTERNATIONAL, INC.

8328 MacArthur Drive • North Little Rock • Arkansas • 72118

www.jasoninternational.com