

## forma<sup>®</sup> Collection Specifications

# Whirlpool & Soaking-RC635

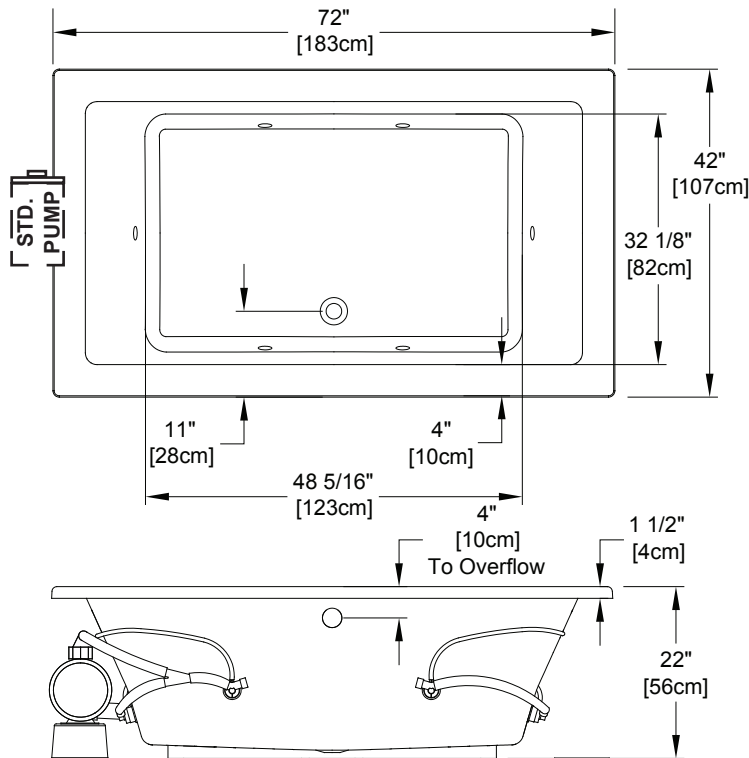

**THIS BATH IS SHOWN WITH THE STANDARD 1 1/2" LIP HEIGHT.**  
**For the optional 3" lip height, please see the next page.**





**NOTE:** To accommodate customer preferences, the control keypad are **not** factory installed on the bath deck. A six (6) foot cable with installation instructions for connecting the control keypad to the control box are provided with all baths.

Patents recieved or pending. Note: Dimensional Tolerances: ±1/4"

<b>Drop-in-Hole Size:</b>	40" x 70"
<b>Operating Capacity:</b>	65 Gal.
<b>Overflow Capacity:</b>	101 Gal.
<b>Floor Loading / sq.ft.:</b>	49.5 lbs.
<b>Carton Wt. (WP/Soaking):</b>	140/101 lbs.
<b>Cube:</b>	46.0 ft. <sup>3</sup>

**Construction:** Fiberglass reinforced acrylic bath with Level Form™ full-support base.

*We provide products listed with Intertek ETL SEMKO (Edison Testing Laboratories) U.S. and Canadian and with International Association of Plumbing and Mechanical Officials (IAPMO). Consult factory with your listing requirements.*

<b>Standard</b>	 <p>A 120v system that includes a 1 1/2 HP, 1-speed pump; an electronic control with a low water level sensor to prevent the pump from operating without water, and a 20-minute timer. The keypad also operates the optional LED Chromatherapy mood light. Requires (1) 20A, 120v circuit. If optional heater is added, (2) 20A, 120v circuits are required.</p>
<b>Signature</b>	 <p>A 240v system that includes a quiet 1 1/2 HP 3-speed pump; digital control with LCD display window, Automatic Ozone System, low water level and water temperature sensors, 20-minute timer, automatic 1.5 kw heater, and a front access Chromatherapy mood light. Bath control keypad operates bath pump, underwater mood light, optional jetted neck pillow and shows water temperature, pump speeds, and time remaining. Includes a floating Universal Remote Control that operates all functions of pump and LED Chromatherapy mood light, plus TV, DVD, CD, etc. Requires (1) 20A, 240v circuit.</p>

## forma<sup>®</sup> Collection Specifications

# Whirlpool & Soaking- RC635



**THIS BATH IS SHOWN WITH THE OPTIONAL 3" LIP HEIGHT.**  
**For the standard 1 1/2" lip height, please see previous page.**

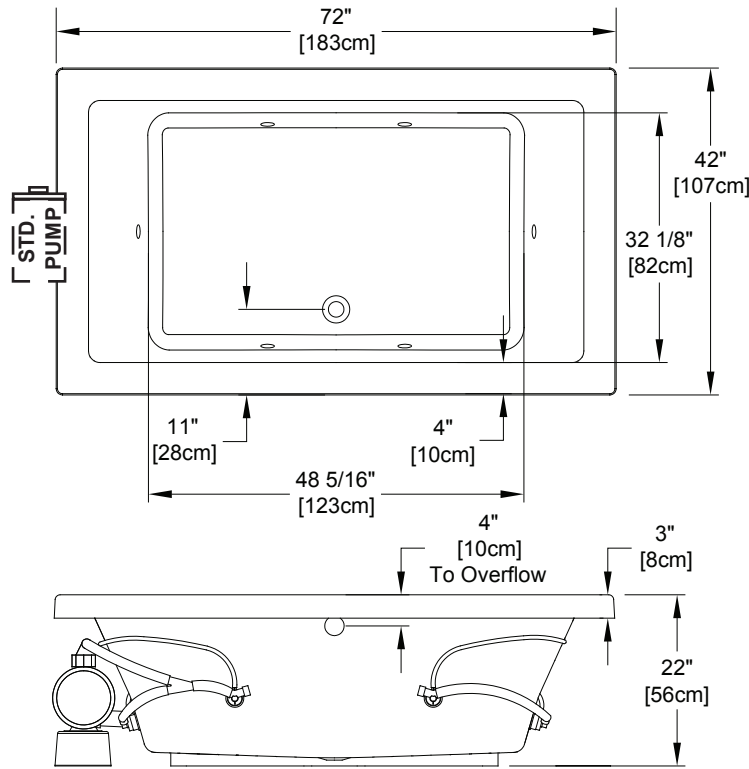



**NOTE:** To accommodate customer preferences, the control keypad are **not** factory installed on the bath deck. A six (6) foot cable with installation instructions for connecting the control keypad to the control box are provided with all baths.

Patents recieved or pending. Note: Dimensional Tolerances: ±1/4"

<b>Drop-in-Hole Size:</b>	40" x 70"
<b>Operating Capacity:</b>	65 Gal.
<b>Overflow Capacity:</b>	101 Gal.
<b>Floor Loading / sq.ft.:</b>	49.5 lbs.
<b>Carton Wt. (WP/Soaking):</b>	140/101 lbs.
<b>Cube:</b>	46.0 ft. <sup>3</sup>

**Construction:** Fiberglass reinforced acrylic bath with Level Form™ full-support base.

*We provide products listed with Intertek ETL SEMKO (Edison Testing Laboratories) U.S. and Canadian and with International Association of Plumbing and Mechanical Officials (IAPMO). Consult factory with your listing requirements.*

<b>Standard</b>	 <p>A 120v system that includes a 1 1/2 HP, 1-speed pump; an electronic control with a low water level sensor to prevent the pump from operating without water, and a 20-minute timer. The keypad also operates the optional LED Chromatherapy mood light. Requires (1) 20A, 120v circuit. If optional heater is added, (2) 20A, 120v circuits are required.</p>
<b>Signature</b>	 <p>A 240v system that includes a quiet 1 1/2 HP 3-speed pump; digital control with LCD display window, Automatic Ozone System, low water level and water temperature sensors, 20-minute timer, automatic 1.5 kw heater, and a front access Chromatherapy mood light. Bath control keypad operates bath pump, underwater mood light, optional jetted neck pillow and shows water temperature, pump speeds, and time remaining. Includes a floating Universal Remote Control that operates all functions of pump and LED Chromatherapy mood light, plus TV, DVD, CD, etc. Requires (1) 20A, 240v circuit.</p>