

forma[®] Collection Specifications **Air-Whirlpool - RE525** with Integral Tile Lip (Drain Left or Right)

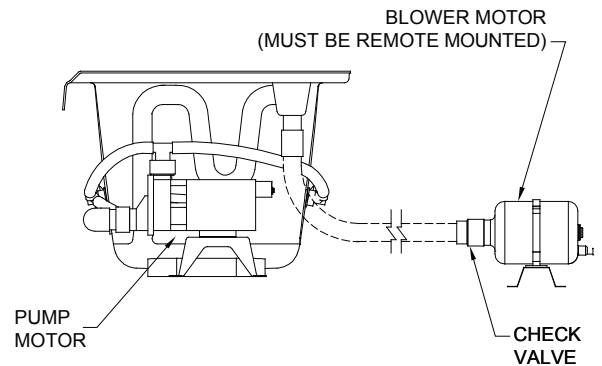

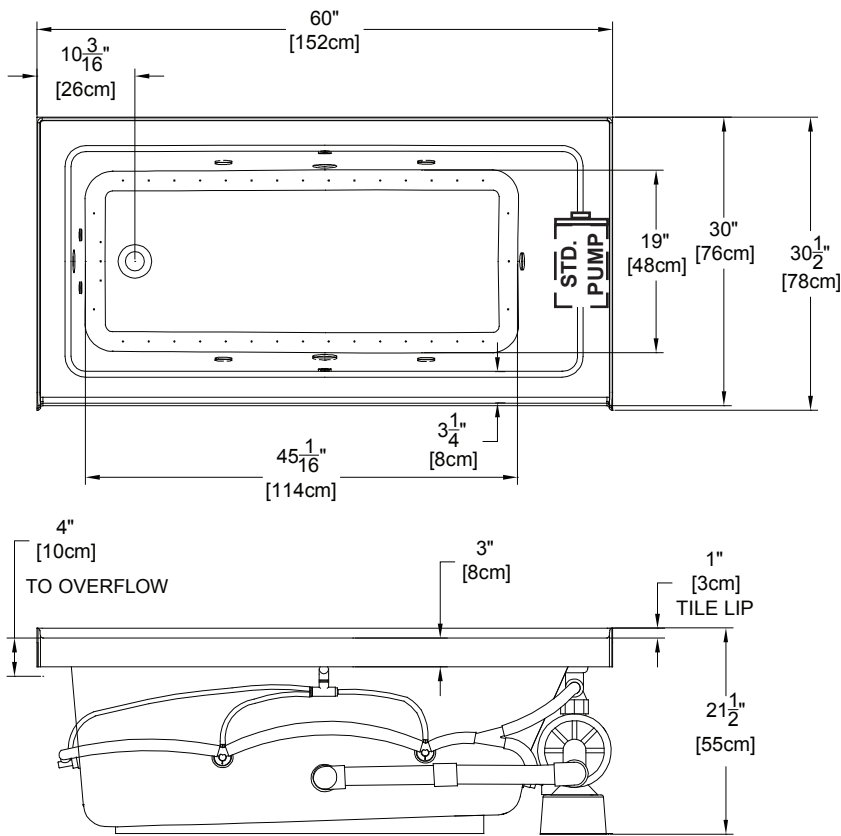

NOTE: To accommodate customer preferences, the control keypad and Sani-Design™ cleaning cap assembly are **not** factory installed on the bath deck. An installation kit for the Sani-Design™ cleaning cap, and a six (6) foot cable with installation instructions for connecting the control keypad to the control box are provided with all baths.

Patents recieved or pending. Note: Dimensional Tolerances: ±1/4"

Drop-in-Hole Size:	N/A
Operating Capacity:	38 Gal.
Overflow Capacity:	60 Gal.
Floor Loading / sq.ft.:	62.6 lbs.
Carton Wt:	156 lbs.
Cube:	26.4 ft. ³

Construction: Fiberglass reinforced acrylic bath with Level Form™ full-support base.

We provide products listed with Intertek ETL SEMKO (Edison Testing Laboratories) U.S. and Canadian and with International Association of Plumbing and Mechanical Officials (IAPMO). Consult factory with your listing requirements.

Standard	 <p>A 120v system that includes a quiet 1-1/2 HP, 1-speed pump and a 120v, 1 HP variable speed air blower with integral air heater and automatic purge cycle. Control keypad operates blower and blower speed for Continuous, Pulse, or Wave massage modes, pump, 20-minute timer, and the optional LED Chromatherapy mood light. Requires (1) 20A GFCI protected circuit for the pump, and (1) 15A GFCI protected circuit for the blower. If optional heater is added, (1) 30A GFCI protected circuit is required for the pump, and (1) 15A GFCI circuit is required for blower.</p>
Signature	 <p>A 240v system that includes a quiet 1-1/2 HP, 3-speed pump, 1 HP variable speed air blower with integral air heater, a front access LED Chromatherapy mood light, a 1.5 kw heater, digital control keypad with LCD display window, Automatic Ozone System, low water level and water temperature sensors, 20-minute timer and an automatic purge cycle. Control keypad operates the 3-speed pump, LED Chromatherapy light, air blower, blower speed, and Continuous, Pulse, or Wave massage modes. Shows water temperature, time remaining, and pump/blower speeds. Includes a floating Universal Remote Control that operates all functions of the whirlpool pump, air blower, and LED Chromatherapy mood light, plus TV, DVD, CD, etc. Requires (1) 20A, 240v GFCI protected circuit.</p>